

Term 1 - Knowledge Organiser (Y8)

Knowledge Organiser Digital Literacy



Unit: Term 1 – Computer Crime & Cyber Security

Year: 8

Purpose of Unit:

- **Understand** a range of ways to use technology safely, respectfully, responsibly and securely, including protecting their online identity and privacy; recognise inappropriate content, contact and conduct and know how to report concerns

Key Learning/Knowledge:

Cybercrime can be committed against individuals, companies, organisations & governments.

How to spot a **Phishing Email** -

- Greeting (they don't know your name)
- Spelling mistakes
- Check sender address
- Requesting personal information
- Sense of urgency

Bad Software that can cause harm and damage your computer. Hackers can often code some bad software to damage your computer.

- Slow it down
- Damage Files
- Lock your computer / files
- Steal your data (files)
- Spy on you (watch what you type)

Why do people **hack**?

- Pure mischief
- Challenge
- To steal money
- To steal or modify information
- For political reasons/revenge

The Data Protection Act:

The principals include:

- Data must be accurate and up to date
- You have a right to see what data is held about you
- The data must be protected from unauthorised access

Ways can we keep your data safe?

- Usernames & passwords
- Encryption
- Locks on doors
- Bars on windows
- Alarms
- Security cameras

Key Vocabulary and meanings:

Phishing – An email that tricks you into handing over personal / sensitive information (often pretending to be a legitimate company)

Malware – Malicious Software designed to cause harm to your computer or the user.

Hacking – is illegally accessing or modifying computer files without permission (Computer Misuse Act 1998)

Virus – Modify, damage or delete files on a computer

Ransomware – Encrypts & locks files until the user pays a ransom.

Computer Misuse Act – Law making it illegal to delete, copy or modify anyone else's computer files without permission.

Data Protection Act - (General Data Protection Regulation) - Law in place to protect personal data.

Data Centres / Server Farms – Large storage facilities (like warehouses) full of large computer servers to store personal data for companies & organisations.

TM Trademark (TM) – Protects logos & phrases of a company from being taken or used by someone else.



Copyright – Protects artistic work from being used without permission (art, film, music, software apps, literature etc.)

Attribution = Giving credit to the artist

Copyright law:

Copyright law protects the owner of a creative work from having it illegally copied
When you see the symbol and text, e.g.

© Copyright David Morris

This means that you are not allowed to copy or redistribute this work

Possible **Health & Safety Concerns** when using a computer / technology:

- Bad Posture, Back Aches, Neck and Shoulder Strain
- Pain in Wrists — Carpal Tunnel Syndrome
- Eye Strain
- UV Blue light
- Headaches
- Physical Fatigue
- Poor Sleep Patterns
- Obesity

Health and Safety regulations:

The law states that an employer must provide:

- tiltable screens
- adjustable chairs
- foot supports
- lighting is suitable
- Tidy un-cramped workstations
- Frequent breaks
- (pay for) appropriate eye and eyesight tests by an optician

Key Skills:

- to be familiar with key laws surrounding the use of technology
- Be aware of common cyber-crime & scams

Royalties - are payments that buy the right to use someone else's property, including copyrighted works.

Plagiarism – Presenting someone else's work as your own.

Health & Safety at work Act – A law that must be followed by employers to keep workers safe at work (with focus on technology)

Ergonomic - Designed for comfort in the working environment



RSI – Repetitive Strain Injury (doing the same movement over and over can cause injury)

E-Waste – Electronic waste (toxic material that comes from electronic devices that can damage the environment)

**Links to prior knowledge/learning:**

Use of Office 365 helpful

No prior knowledge or learning needed for this unit

Cross Curricular link/ World Issues

Safe use of technology in business

Music and Media cross-over with 'copyright' issues

Royalties within the music industry

Term 2 - Knowledge Organiser (Y8)

Knowledge Organiser Digital Literacy



Unit: Term 2 – Understand Computers

Year: 8

Purpose of Unit:

- **Understand how to...** what makes up a computer system.
- **To know...** where computer systems are used in everyday life.
- **To be able to...** explain key components of a computer systems and how they communicate together to share data. (fetch-decode-execute)

Key Learning/Knowledge:



Input Devices:	Output Devices	Storage Devices:
Mouse Keyboard Digital Camera Microphone Touch screen Fingerprint scanner Barcode scanner Motion Sensor (any sensor)	Monitor (screen) Printer Speakers Headphones Projector	Hard Disc Drive (HDD) Solid State Drive (SSD) CD - Compact Disc USB Flash Drive

Examples of **embedded systems** include:

- central heating systems
- engine management systems in cars
- Home appliances, such as dishwashers and TVs
- digital watches
- electronic calculators
- GPS systems (SAT Nav)
- fitness trackers

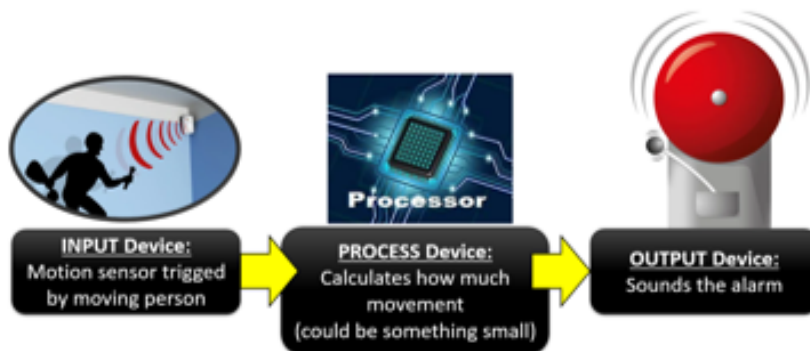

Key Vocabulary & meanings:

Computer System – interconnected devices....
Input > Process > Output

Process – computer performing calculations (doing something with input data)

Hardware – Physical component you can touch

Software – App on computer (written code)

Storage – hardware device used to storage digital data (picture, music, videos, files, apps etc.)

Embedded Computer System – used for a dedicated purpose (microwave, washing machine, cash machine) Limited number of tasks it can perform.

Autonomy - It means that we can program a computer to **automatically** do tasks.

Internal – a hardware device inside the machine

External – a hardware device outside the machine

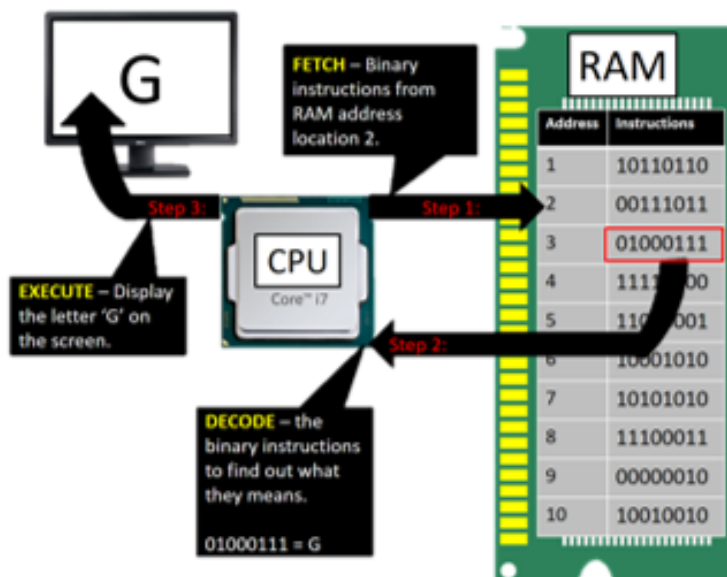

CPU – Central Processing Unit (performs calculations with binary data inside the computer)

Motherboard – Main circuit board inside the computer that every component connects too.

RAM – Random Access Memory (short term memory inside the computer for current programs / apps open) only for when computer is on.

ROM – Read Only Memory remembers how to start up a computer. (boot-up)

Hard Disc Drive – Main storage inside the computer to save and store files (see 'storage' above)

Solid State Drive – Main storage inside the computer (new version) no moving parts and can be made smaller for pocket sized devices like smart phones.

Clock Speed – instructions processed per second Measured in.....**Hertz** (cycles per second)

STORAGE MEMORY SIZE:

- Bit = (1 or 0)
- Byte = (10101101) or a 'letter' or 'symbol' on keyboard
- KB = Kilobyte (an email or text document)
- MB = Megabyte (a photo or song)
- GB = Gigabyte (a movie)
- TB = Terabyte (hundreds of movies)
- PB = Petabyte (thousands of movies)

CLOCK SPEED:

- 1 **hertz** (1 instruction per second)
- 1 **kilohertz** (1,000 instructions per second)
- 1 **Megahertz** (1,000,000 instructions per second)
- 1 **Gigahertz** (1 Billion instructions per second)

Key Skills:

- To be familiar with key components used in comp systems.
- Be able to explain the 'fetch-decode-execute' cycle.
- Be aware of common terminology used

Links to prior knowledge/learning:

Use of Office 365 helpful
Some basic knowledge of basic input-output components (helps)

Cross Curricular link/ World Issues

Technology used in real world situations
Embedded computer systems making life easier for different groups of people
Numeracy with numbers (binary, size measurements of data size & speed of processors)

Term 3 - Knowledge Organiser (Y8)

Knowledge Organiser Computer Science

Unit: Term 2 – Python Year: 8	
Purpose of Unit: <ul style="list-style-type: none"> • Understand... why coding is important in everyday life • To know... the basic programming commands and syntax in Python • To be able to... code using 'sequence, selection & iteration code' 	
Key Learning/Knowledge: Algorithms can be displayed a number of different ways... <ul style="list-style-type: none"> • Plain English • Flowcharts • Pseudocode • Programming Language 	
Example of an algorithm displayed using a 'Flowchart'	Common Flowchart symbols used when creating a flowchart for an algorithm.
Examples of key Pseudocode command words when writing out instructions using Pseudocode.	
<div style="border: 1px solid red; padding: 5px;"> <p>PSEUDOCODE: INPUT –user will be inputting something OUTPUT –outputs that might appear WHILE – a loop while a certain condition is met FOR – a counting loop (how long) REPEAT – UNTIL IF – THEN – ELSE – a decision (selection) a choice</p> </div>	Key Vocabulary & meanings: Algorithm – step-by-step instructions to perform a task (solve a problem) Flowchart – a way of displaying an algorithm Pseudocode – false code. Used to plan before coding for real. Using keywords (see below). Input – how data enters the system (keyboard command, motion sensor, button etc.) Process – calculations with data (doing something with input data like calculating time, or a total cost) Output – information provided by the system (printed out on the screen as text) Decision – allowing two options (Boolean option: <u>Example:</u> <ul style="list-style-type: none"> • Yes or No • True or False • On or Off • 1 or 0 FOR – Loop for a certain number of times. WHILE – Loop while a condition is true.



Python Programming Language:
 "A programming language is a vocabulary and set of grammatical rules for instructing a computer to perform specific tasks"

What is computer Programming?

It is the process of **writing, testing, debugging/troubleshooting,** and maintaining the source code of computer programs. This source code is written in a programming language.

Programming Language:

"A programming language is a vocabulary and set of grammatical rules for instructing a computer to perform specific tasks"

"A set of **rules symbols** and **special words** used to construct a computer program."

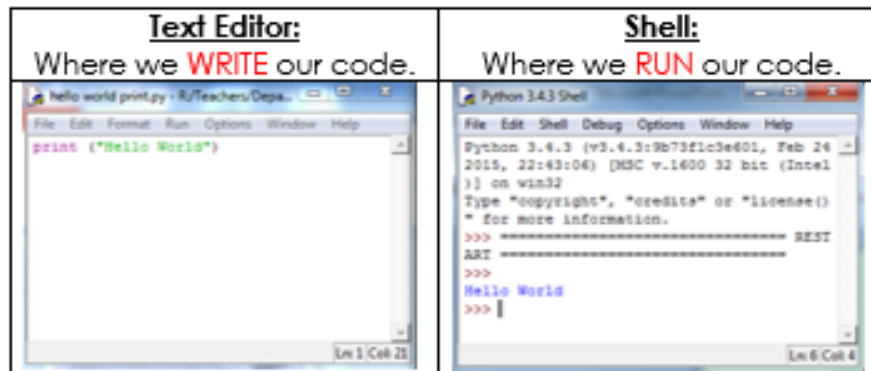

Print Function:

The 'print' function is **an output command** used to display information on the screen.

```
print ("Hello")
```

Syntax error:

In computer science, the syntax error is a **mistake in the code** that must be correct in order for the code to run properly.

These are often highlighted in the Python shell.

Variable:

A variable is something that **can change. (and stored)** This means we can collect different information in the code as an input and then use this information later when needed.

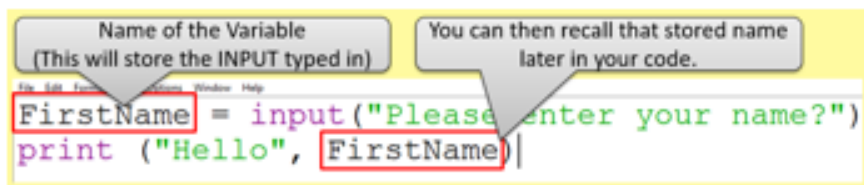

Iteration– technical term for when code is repeated. (a loop)

Python– Name of the programming language

Sequence– When code is displayed line-by-line (in order)

Variable – data that can change (and be stored for later use)

Syntax Error – Error in the code (typically missing speech marks or brackets)

String – string of text or words in your code

Integer– Whole number used for calculations. Is a data type.

DATA:	DATA TYPE:
Dog	String
18	Integer
Kelly18	String

Arithmetic Operators –

- + Addition
- Subtraction
- * Multiplication
- / Division

Selection Code– Use to select a specific line of code to run based on a 'true' or 'false' decision.

Arithmetic Operators can be used to perform **calculations** in code.

```
File Edit Format Run Options Window Help
print (5*5)
print (5/5)
print (5+5)
print (5-5)
```

Assigning Integer Variables – in order to collect variables and perform calculations with them, you must assign them as integers as seen below.

```
File Edit Format Run Options Window Help
number1=int(input("Please enter a number:"))
number2=int(input("Please another number:"))

print (number1+number2)
```

Selection Code – this type of code allows use to perform a boolean check (**True or False**). It can be **used to make decisions** in code.

You can see it is checking if the 'Password' (entered and stored above as a variable) is the same as "Letmein123"

```
Password = input("Please enter your password:")

if Password == "Letmein123":
    print ("Welcome to the system")
else:
    print ("incorrect password")
```

True Option →
False Option →

Note: The two indented lines for if the check is 'True' or 'False'

Key Skills:

- To understand the term algorithm.
- To be able to use, print commands, variables and selection (IF, ELSE) code.
- Be able to identify syntax errors.
- Be aware of common terminology used

Links to prior knowledge/learning:

Use of Office 365 helpful

Knowledge of algorithm steps and scratch can help structure code.

Some basic knowledge of basic input-output components (helps)

Cross Curricular link/ World Issues

Programming used in real world situations / careers and industry

Embedded computer systems making life easier for different groups of people



Numeracy with numbers (calculations, mathematical operators)

Problem solving to produce a solution in code.

Term 4 - Knowledge Organiser (Y8)

How Computers Work







Key Terms	Definition	Examples	RA G																											
Binary	<p>Binary is a number system that only uses two digits: 1 and 0. All information that is processed by a computer is in the form of a sequence of 1s and 0s.</p> <p>The binary system is known as a 'base 2' system. This is because:</p> <ul style="list-style-type: none"> there are only two digits to select from (1 and 0) 																													
Denary / Decimal	<p>Denary is a number system most used by people. This system has 10 digits that we can use: 0, 1, 2, 3, 4, 5, 6, 7, 8 and 9. Also known as 'decimal' or 'base 10' system.</p>	<p>Working out the value of 1024</p> <table border="1"> <thead> <tr> <th>Thousands (1000s)</th> <th>Hundreds (100s)</th> <th>Tens (10s)</th> <th>Units (1s)</th> </tr> </thead> <tbody> <tr> <td>1</td> <td>0</td> <td>2</td> <td>4</td> </tr> <tr> <td>$1 \times 1000 +$</td> <td>$0 \times 100 +$</td> <td>$2 \times 10 +$</td> <td>4×1</td> </tr> </tbody> </table>	Thousands (1000s)	Hundreds (100s)	Tens (10s)	Units (1s)	1	0	2	4	$1 \times 1000 +$	$0 \times 100 +$	$2 \times 10 +$	4×1																
Thousands (1000s)	Hundreds (100s)	Tens (10s)	Units (1s)																											
1	0	2	4																											
$1 \times 1000 +$	$0 \times 100 +$	$2 \times 10 +$	4×1																											
Binary Addition	<p>There are four rules that need to be followed when adding two binary numbers. These are:</p> <ul style="list-style-type: none"> $0 + 0 = 0$ $1 + 0 = 1$ $1 + 1 = 10$ (binary for denary 2) $1 + 1 + 1 = 11$ (binary for denary 3) 																													
ASCII	<p>American Standard Code for Information Interchange (ASCII) – A 7-bit character set used for representing English keyboard characters.</p>	<table border="1"> <thead> <tr> <th>Character</th> <th>Denary</th> <th>Binary</th> </tr> </thead> <tbody> <tr> <td>A</td> <td>65</td> <td>1000001</td> </tr> <tr> <td>Z</td> <td>90</td> <td>1011010</td> </tr> <tr> <td>a</td> <td>97</td> <td>1100001</td> </tr> <tr> <td>z</td> <td>122</td> <td>1111010</td> </tr> <tr> <td>0</td> <td>48</td> <td>0110000</td> </tr> <tr> <td>9</td> <td>57</td> <td>0111001</td> </tr> <tr> <td>Space</td> <td>32</td> <td>0100000</td> </tr> <tr> <td>!</td> <td>33</td> <td>0100001</td> </tr> </tbody> </table>	Character	Denary	Binary	A	65	1000001	Z	90	1011010	a	97	1100001	z	122	1111010	0	48	0110000	9	57	0111001	Space	32	0100000	!	33	0100001	
Character	Denary	Binary																												
A	65	1000001																												
Z	90	1011010																												
a	97	1100001																												
z	122	1111010																												
0	48	0110000																												
9	57	0111001																												
Space	32	0100000																												
!	33	0100001																												
Logic Gates	<p>Computers are made up of digital circuits. A logic gate is the building blocks of these circuits and they work by using two binary conditions:</p> <p>Low voltage (0) and high voltage (1).</p> <p>Logic gates have inputs and outputs. The voltage may change as it passes through the gate.</p>																													

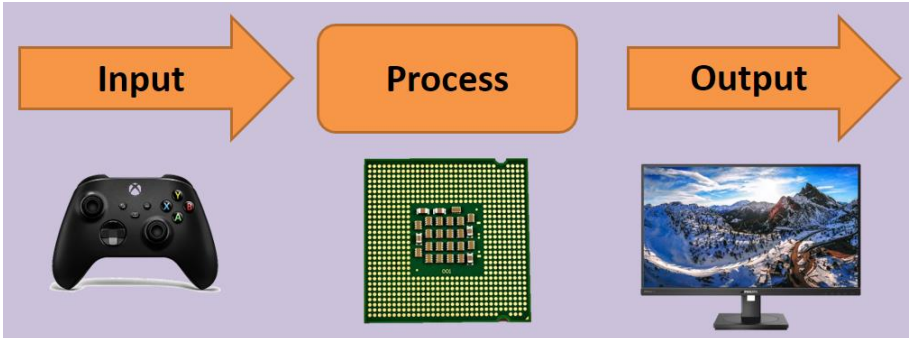
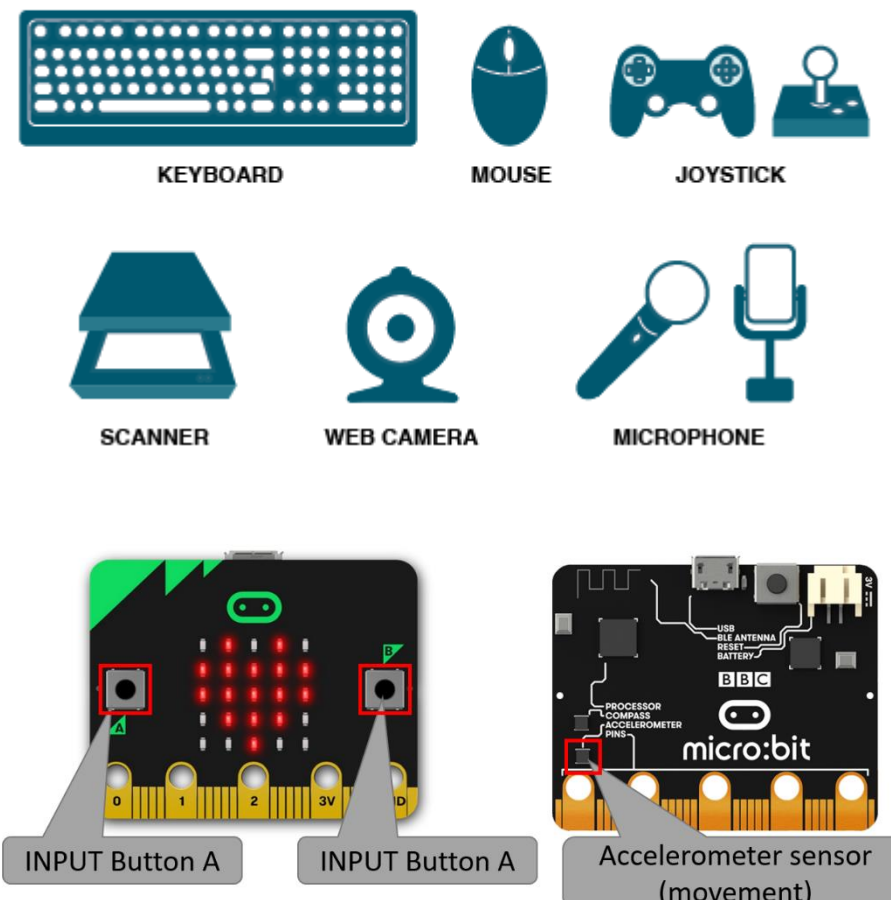

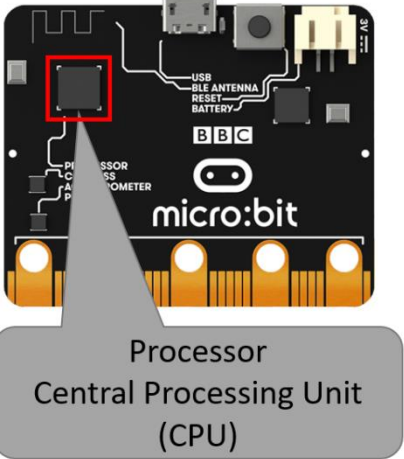
<p>AND Gate</p>	<p>An AND gate uses two inputs to generate one output.</p> <p>The output is 1 (TRUE) only if both of the inputs are 1 (TRUE).</p>	<p>AND gates are represented diagrammatically as:</p>  <p>A represents the first input. B represents the second input. Q represents the output.</p> <p>An AND gate is represented in the truth table below.</p> <table border="1" data-bbox="762 443 1422 616"> <thead> <tr> <th>A</th> <th>B</th> <th>Q</th> </tr> </thead> <tbody> <tr> <td>0</td> <td>0</td> <td>0</td> </tr> <tr> <td>0</td> <td>1</td> <td>0</td> </tr> <tr> <td>1</td> <td>0</td> <td>0</td> </tr> <tr> <td>1</td> <td>1</td> <td>1</td> </tr> </tbody> </table>	A	B	Q	0	0	0	0	1	0	1	0	0	1	1	1						
A	B	Q																					
0	0	0																					
0	1	0																					
1	0	0																					
1	1	1																					
<p>OR Gate</p>	<p>An OR gate uses two inputs to generate one output.</p> <p>The output is 1 (TRUE) only if either or both of the inputs are 1 (TRUE).</p>	<p>OR gates are represented diagrammatically as:</p>  <p>A represents the first input. B represents the second input. Q represents the output.</p> <p>An OR gate is represented in the truth table as below.</p> <table border="1" data-bbox="762 974 1422 1153"> <thead> <tr> <th>A</th> <th>B</th> <th>Q</th> </tr> </thead> <tbody> <tr> <td>0</td> <td>0</td> <td>0</td> </tr> <tr> <td>0</td> <td>1</td> <td>1</td> </tr> <tr> <td>1</td> <td>0</td> <td>1</td> </tr> <tr> <td>1</td> <td>1</td> <td>1</td> </tr> </tbody> </table>	A	B	Q	0	0	0	0	1	1	1	0	1	1	1	1						
A	B	Q																					
0	0	0																					
0	1	1																					
1	0	1																					
1	1	1																					
<p>NOT Gate</p>	<p>A NOT gate uses just one input to generate one output. A NOT gate inverts the input.</p> <p>The output is 1 (TRUE) if the input is 0 (FALSE), and the output is 0 (FALSE) if the input is 1 (TRUE).</p>	<p>NOT gates are represented diagrammatically as:</p>  <p>The NOT gate has what appears to be a nose at the front. When using more complex gates, this nose is added to other gates to show they have been combined with the NOT gate.</p> <p>A NOT gate is represented in the truth table below.</p> <table border="1" data-bbox="762 1523 1422 1646"> <thead> <tr> <th>A</th> <th>Q</th> </tr> </thead> <tbody> <tr> <td>0</td> <td>1</td> </tr> <tr> <td>1</td> <td>0</td> </tr> </tbody> </table>	A	Q	0	1	1	0															
A	Q																						
0	1																						
1	0																						
<p>Boolean Logic</p>	<p>Programs use simple comparisons to help make decisions. Boolean logic is a form of algebra where all values are either True or False. These values of true and false are used to test the conditions that selection and iteration are based around.</p>	<table border="1" data-bbox="762 1668 1422 1960"> <thead> <tr> <th>Expression</th> <th>Boolean equivalent</th> </tr> </thead> <tbody> <tr> <td>Equals</td> <td>=</td> </tr> <tr> <td>Greater than</td> <td>></td> </tr> <tr> <td>Less than</td> <td><</td> </tr> <tr> <td>Greater than or equal to</td> <td>>=</td> </tr> <tr> <td>Less than or equal to</td> <td><=</td> </tr> <tr> <td>Does not equal</td> <td><></td> </tr> <tr> <td>And</td> <td>AND</td> </tr> <tr> <td>Or</td> <td>OR</td> </tr> <tr> <td>Not</td> <td>NOT</td> </tr> </tbody> </table>	Expression	Boolean equivalent	Equals	=	Greater than	>	Less than	<	Greater than or equal to	>=	Less than or equal to	<=	Does not equal	<>	And	AND	Or	OR	Not	NOT	
Expression	Boolean equivalent																						
Equals	=																						
Greater than	>																						
Less than	<																						
Greater than or equal to	>=																						
Less than or equal to	<=																						
Does not equal	<>																						
And	AND																						
Or	OR																						
Not	NOT																						

Term 5 - Knowledge Organiser (Y8)

How Computers Work

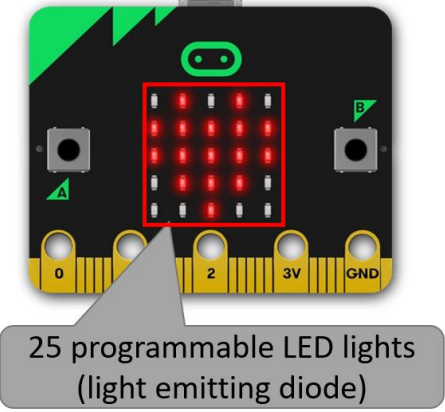
Key Terms	Definition	Examples	RAG
<p>Computer system</p>	<p>A computer is a device that <u>can be programmed to carry out sequences of instructions.</u></p>		
<p>Input</p>	<p>A device used to input data into the computer</p>	<p style="text-align: center;">INPUT DEVICES</p> 	

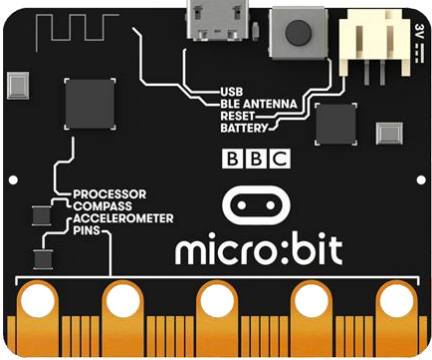
<p>process</p>	<p>The microchip inside the computer that allows you to</p>		
<p>Output</p>	<p>A device used to provide information back to the user</p>	<h2 style="text-align: center;">OUTPUT DEVICES</h2> <div style="display: flex; justify-content: space-around; align-items: center;"> <div style="text-align: center;">  <p>MONITOR</p> </div> <div style="text-align: center;">  <p>PRINTER</p> </div> <div style="text-align: center;">  <p>SPEAKER</p> </div> </div> <div style="display: flex; justify-content: space-around; align-items: center; margin-top: 20px;"> <div style="text-align: center;">  <p>HEADPHONES</p> </div> <div style="text-align: center;">  <p>PROJECTOR</p> </div> </div> <div style="text-align: center; margin-top: 20px;">  </div>	

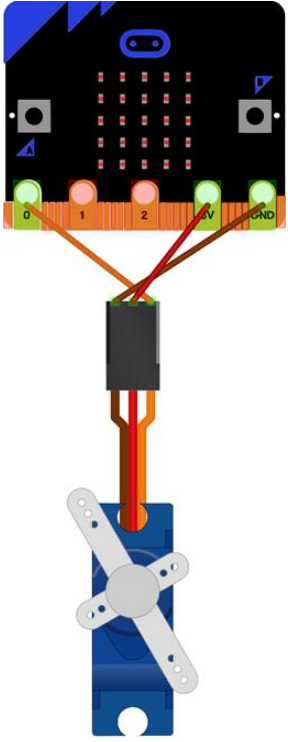
<p>Micro-bit</p>	<p>A small programmable computer</p>		
<p>LED</p>	<p>Light emitting diode (that make up the 25 programmable LED lights on the micro-bit to show text and images)</p>		
<p>I/O connectors</p>	<p>Input / output connectors</p>		
<p>Processor</p>	<p>Central Processing Unit – used to perform calculations with binary data. (converts signals to instructions)</p>		

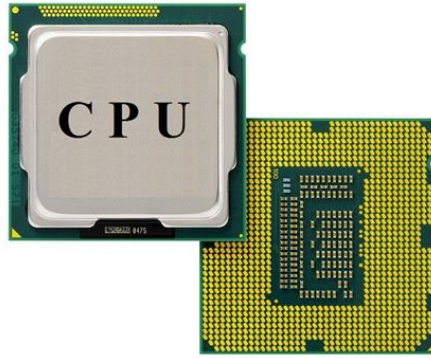

Accelerometer

Used to detect / sense movement of the device

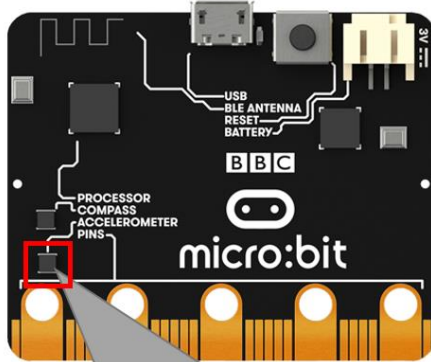

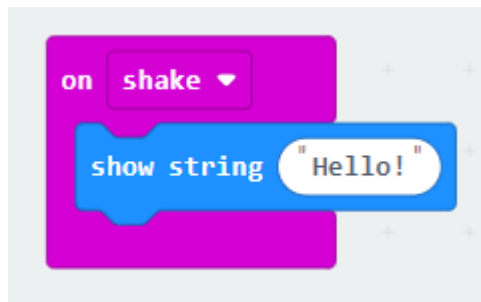

Accelerometer sensor (movement)

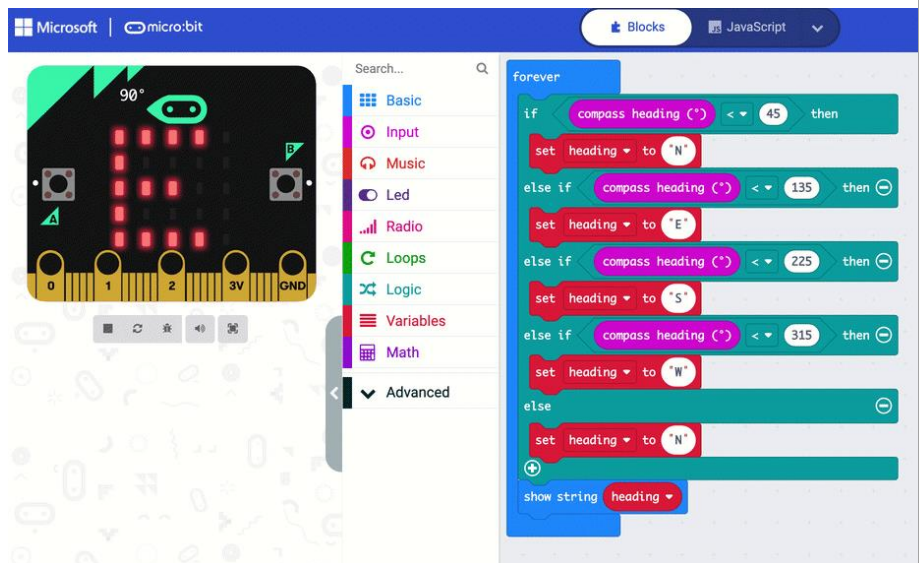

Magnetometer

Used to detect which way the device is facing (compass)

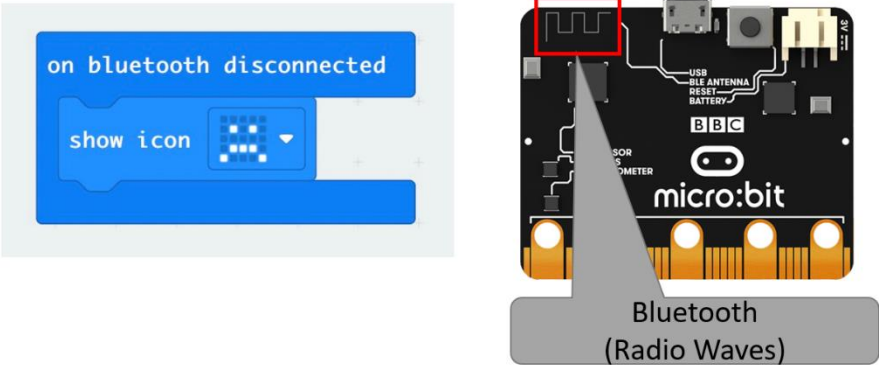

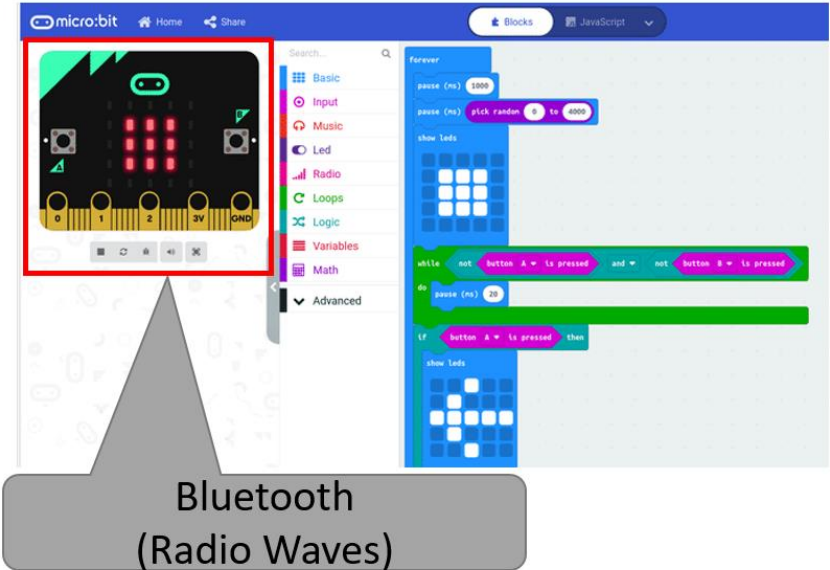
<p>Bluetooth</p>	<p>Can wirelessly send and receive signals by radio waves</p>		
<p>USB connector</p>	<p>Universal Serial Bus – used to connect a device to the computer</p>		
<p>Emulator</p>	<p>Allows you to test your code on a virtual simulator of the Micro-bit (top right corner of coding software)</p>		

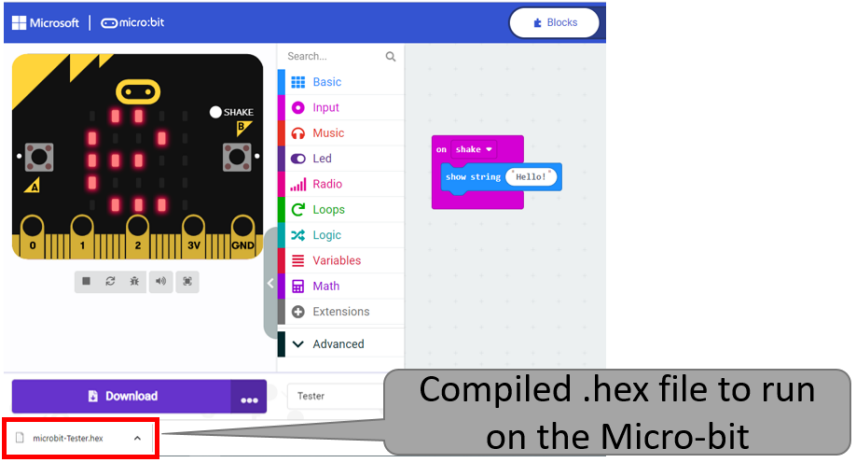
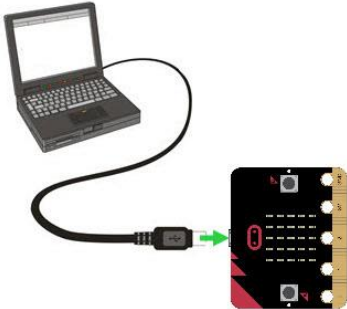
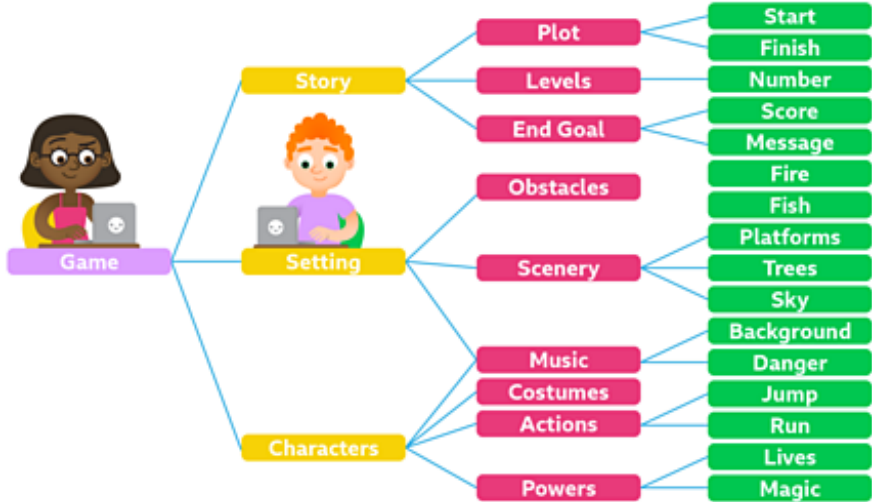
<p>Compile</p>	<p>The process of converting the code into a language the Micro-bit will understand.</p>		
<p>Flash</p>	<p>The process of transferring the program (code) onto the Micro-bit device.</p>		
<p>Decomposition</p>	<p>Breaking down a problem (Process used to consider steps of the algorithm) Used in planning stages of coding.</p>		
<p>Abstraction</p>	<p>Removing any unnecessary parts of the algorithm steps once they have been broken down.</p>		

<p>Algorithm</p>	<p>Step by step instructions to solve a problem (can be shown in writing or flowchart)</p>	<pre> graph TD Start([Start]) --> Input[/Input 'Which is the best subject?'/] Input --> Decision{Does answer = 'Computer Science?'} Decision -- NO --> Output1[/Output 'Try again!'/] Output1 --> Input Decision -- YES --> Output2[/Output 'Of course it is!'/] Output2 --> Stop([Stop]) </pre>	
<p>Variable</p>	<p>Used to store data in code. (change change)</p>		
<p>Selection code</p>	<p>IF, ELSE code. Used to make a TRUE or FALSE decision in code.</p>		

Logic

TRUE or FALSE

```
on button A pressed
  if true then
    show string "Button A has been pressed"
  else
    show string "Button B has been pressed"
```

Sorting

Organising data into some sort of order.

Ascending and Descending Order

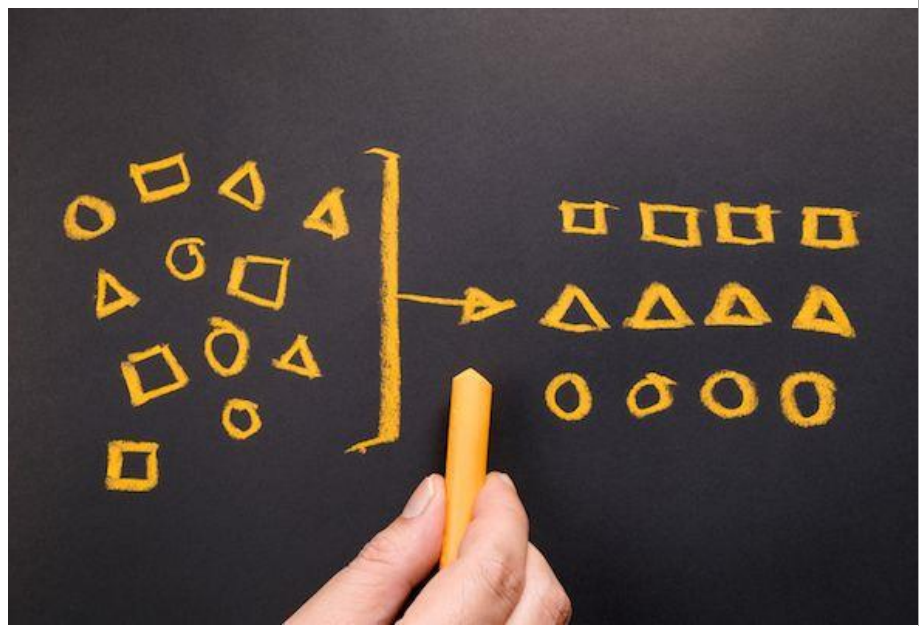

Bubble Sort

A method of sorting data by comparing 2 numbers next to each other in a list and then switching depending on which is highest.

Example Bubble Sort Pass

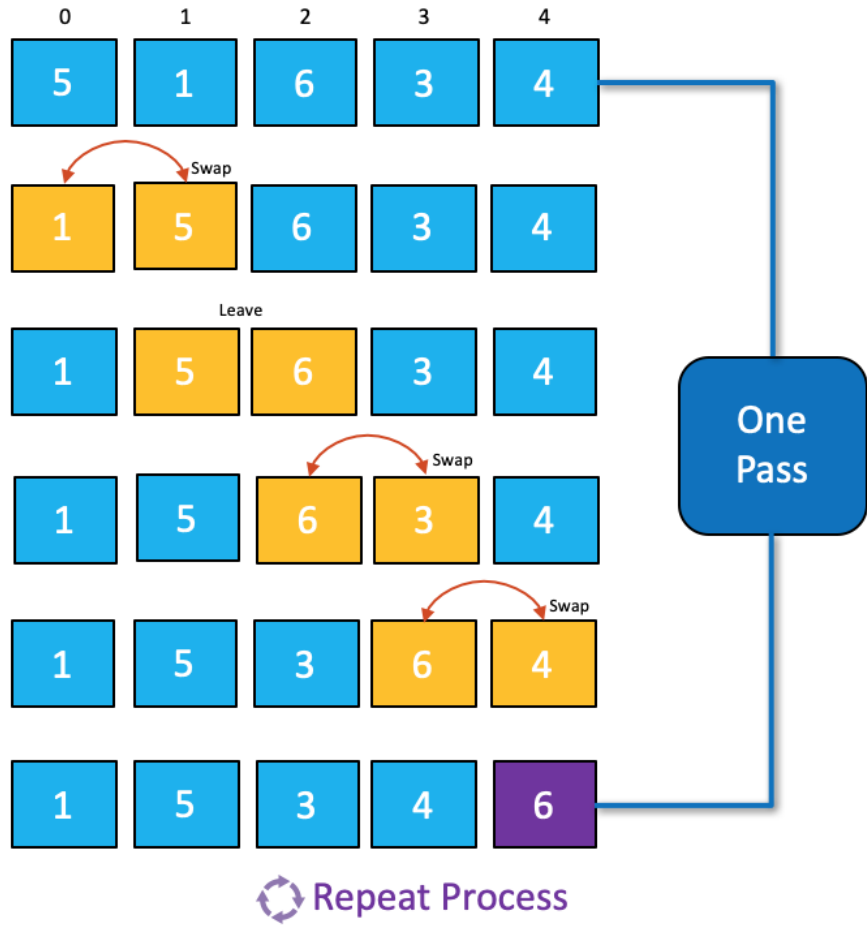

Comparison operators

Used to compare to pieces of data.

Greater than example: $5 > 3 = \text{TRUE}$
Less than example: $5 < 3 = \text{FALSE}$
Equals to example: $5 == 5 = \text{TRUE}$

Operator Symbol	Operator Name	Description
=	Equal to	Compares One Value to Other Value
>	Greater Than	Tests whether the value is greater than certain value or not
<	Less Than	Tests whether the value is less than certain value or not

Loops

Logic

Variables

Math

Extensions

Advanced

Comparison







Term 6 - Knowledge Organiser (Y8)

Key Terms	Definition	Examples	RAG
<p>Airbrushing =</p>	<p>alter or change (a photograph) using an airbrush. "a picture of a man with wings airbrushed on to his shoulders"</p>		
	<p>We tend to see airbrushed images in....</p>	<ul style="list-style-type: none"> • Social media • Websites • Adverts • Magazines • Movie / Posters • Television 	
	<p>How to spot an edited image...</p>	<ul style="list-style-type: none"> • Look for unrealistic or flawless skin: Airbrushing often involves smoothing out imperfections, so if the skin appears too perfect, without any blemishes, wrinkles, or pores, it might be a sign of editing. • Pay attention to lighting and shadows: Inconsistent or unrealistic lighting and shadows in the photo can indicate manipulation, especially if they don't align with the subject or other objects in the image. • Check for blurred edges (halos): Poorly executed airbrushing can result in blurred edges or halos around the subject, especially when they have been cut out and placed onto a different background. • Look for reflections: If there are reflective surfaces in the photo, such as mirrors or glass, examine them closely for any inconsistencies or distortions that don't match the rest of the image. 	
	<p>Why do people edit images?</p>	<ul style="list-style-type: none"> • To sell a product • To get 'likes' • To get 'followers' • For Fun • To stir / create fake news • To cause controversy (divide) 	

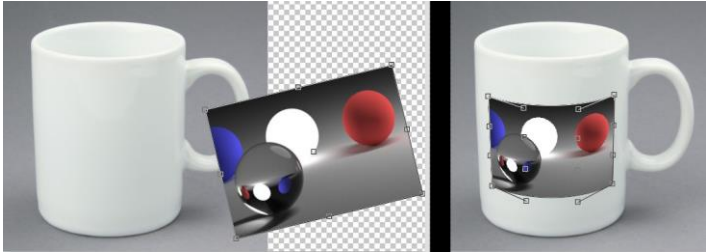
<p>Social impact</p>	<p>This may have an issue on members of society feeling they want to look like the 'perfect' unattainable image and left feeling inadequate.</p>	<p>Example: This issue could lead to many young people feeling lost, inadequate and lead to depression and anxiety about their own body image. Perhaps they don't realise what they are seeing isn't real?</p> <p>Viewers feeling:</p> <ul style="list-style-type: none"> • Angry • Upset • Cheated • Pressured • Anxiety • Confused 	
	<p>What can this lead to...</p>	<ol style="list-style-type: none"> 1. Unrealistic Beauty Standards: Airbrushed images create a false idea of what people should look like. They make it seem like everyone has perfect skin, bodies, and features. This can make young teenagers feel like they need to look the same way, which can harm their self-esteem. 2. Body Image and Self-Esteem: Seeing airbrushed images can make teenagers feel insecure about their own appearance. They may compare themselves to these edited images and think they're not good enough. This can lead to low self-esteem and body image issues. 3. Pressure to fit in: Airbrushed images can put pressure on teenagers to try and look like the edited versions. They may feel the need to change their bodies, wear makeup, or do other things to match the unrealistic beauty standards they see online. This pressure to conform can be stressful and unhealthy. 4. Negative Effects on Mental Health: Constant exposure to airbrushed images can contribute to feelings of anxiety, depression, and dissatisfaction with one's own appearance. It's important for teenagers to understand that these images are not realistic and that everyone is unique and beautiful in their own way. <p>It's crucial for young teenagers to develop digital literacy skills. This means understanding that the images they see are often edited and</p>	

		<p>don't reflect reality. By learning to recognise 'airbrushing' and understanding its impact, teenagers can develop a healthier relationship with media and build stronger self-confidence.</p>	
Photograph rights		<p>The rights to a photograph typically belong to the person who took the photograph, known as the photographer. (NOTE: unless being paid as part of their job to carry out the work for a company / business)</p>	
Moral Impact	<p>The people creating these photos have a moral decision to make when taking and editing pictures for the public.</p>	<p>Example: Should a celebrity let the public know that their image has been edited? Should this message be included with the image? Should photo editing be allowed?</p>	
	<p>Factors to consider when editing an image...</p>	<ul style="list-style-type: none"> • Content of the images • Lighting • Size • Angle • Colour 	
Propaganda (Prop-a-gan-da)		<p>Information that is biased or misleading, used to promote a particular political cause or point of view.</p>	
 Zoom tool	<p>The Zoom tool allows you to zoom in and zoom out at different places of the image. Just select the tool (in the toolbar on the left) and click on the image. You can switch between zooming in and zooming out in the top panel, or by pressing the Alt key on the keyboard. You can also click and drag to the right to zoom in, or drag to the left to zoom out. There is a quick mode for the Zoom tool. By pressing Ctrl + Spacebar, you will switch to the Zoom tool, which you can use in a regular way. E.g. you can add or release Alt to switch between zooming in and zooming out. After</p>		

	<p>releasing the keyboard keys, you will return back to the previous tool. It is one of the fastest ways to zoom.</p>		
 <p>Free Transform</p>	<p>Free Transform is the basic tool for doing transformations. It works as any other regular tool, but it is not present in the toolbar. You can enable it by clicking Edit - Free Transform, or Alt + Ctrl + T.</p>		
 <p>Lasso</p>	<p>Lasso tool allows you to draw selections by hand. Simply click and drag the mouse around the object, that you want to select. It can be useful to zoom in, to be more precise.</p>		
 <p>Polygonal Lasso</p>	<p>Polygonal lasso allows you to draw a polygonal selection. Simply click on the image to add the new corner of a polygon. Press Delete to remove the last corner. Double-click (or hit Enter) to finish the selection.</p>		
	<p>Magnetic lasso is a smart tool for making selections. It is very similar to the</p>		

Magnetic Lasso



standard lasso, but it "sticks" to edges of objects. Click anywhere to add the first point, then move the mouse along the edge to draw the selection. Control points will be added along the selection. Magnetic lasso tries to find the most appropriate path from the last control point to the current position of the mouse. Press Delete to remove the last control point, or click to add the control point manually (to force Magnetic lasso to go in a specific way). Double-click (or hit Enter) to finish the selection.

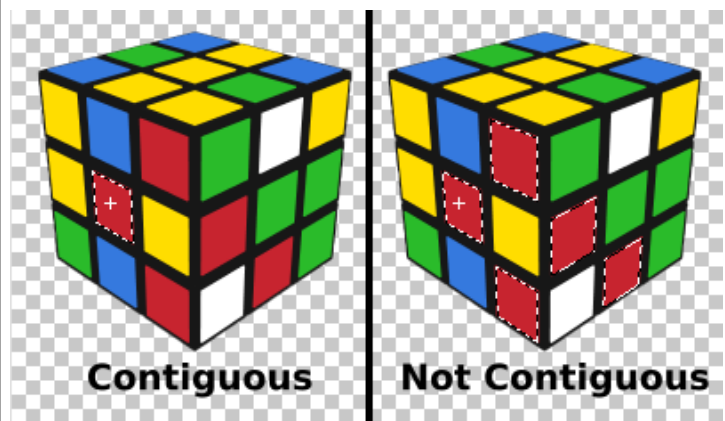

Magic Wand

Magic wand allows you to select pixels with the same (or similar) colour. Once you click somewhere with the Magic Wand, the pixel under the mouse will be selected, as well as all other pixels, that have a colour similar to that pixel. There is a **Contiguous mode** option (in the top menu). When it is on, the Magic Wand will select only those similar pixels, that are connected to the source pixel (i.e. it will select the whole area, that has the same colour, but not other areas, which are separated from this area). When this option is disabled, the Magic Wand will select all similar pixels from the whole image, even if they are not connected to the source pixel. Here you can see the result of clicking on the pixel



	<p>(marked by the white cross) with the Contiguous mode enabled and disabled.</p> <p>There is also a Tolerance parameter in the top menu, which defines how much similar colours you want to select (larger values produce "wider" selections).</p>		
 <p>Clone Stamp</p>	<p>Clone stamp lets us copy the content from one part of the layer into another part. First, we hold the Alt key and click on the layer, to choose the source of cloning. Then we simply draw strokes in another part, which are filled with the content from the source part. Decrease the Hardness of a brush, so that new strokes have smooth edges, to make a smooth transition between the old and the new content.</p>		
 <p>Blur and Sharpen</p>	<p>These tools simply blur or sharpen the content of the layer under the stroke. You can change the Strength of the effect at the top menu.</p>		
 <p>Dodge</p> <p>Burn</p>	<p>Dodge makes the colours lighter, while Burn makes the colours darker. You can choose the range, to which the effect should be applied (Shadows / Tones / Highlights) and the strength (Exposure).</p>		



The Smudge tool is probably the most advanced these tools. It is the analogy of moving your finger across the wet paint on the painting. You can spread colours to other areas, make object longer or shorter, or move the border between two objects.

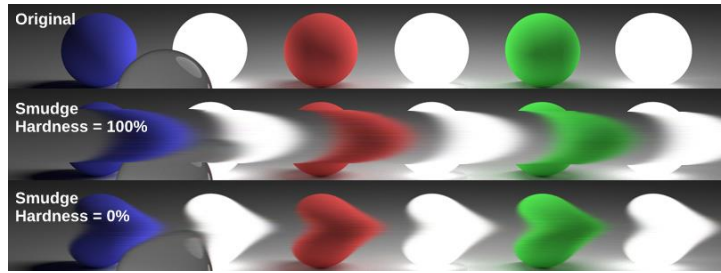

Spot Healing brush lets you remove objects and unwanted artefacts from pictures. Simply draw over an unwanted area, just like you do with a Brush tool, and release the mouse. After that, the area, that you drew over, will be "forgotten" and replaced with some appropriate content, that surrounds the area.

